



A JohnsonDiversey Company

# CMA-180

High Temperature  
Single Rack  
Dishwasher

Item. # \_\_\_\_\_

Spec. # \_\_\_\_\_

## FEATURES:

- 60 racks / 240 covers per hour.
- Economical to operate. Uses only .96 gallons of water per cycle.
- Automatic soil purging system. Filters wash water and traps plate debris into an external tray. Tray can be easily removed for dumping contents.
- Heavy duty 12 and 14 gauge 304 stainless steel construction offers durable performance and years of trouble free operation.
- Built-in chemical resistant industrial 5kW heater and optional 12kW booster heater are proven to be more durable than commercial style heaters.
- Unique spray arm system features upper and lower stainless steel wash arms with reinforced end caps. Specially designed pull-pins allow wash arms to be easily removed for cleaning.
- Top mounted control box is water tight and includes a rack counter, extended wash/delimer switch and easy to read temperature gauges.
- Auto start/stop makes operation safe and easy.
- Field convertible for a wide range of applications.



Corner Model



Top mounted control box is water tight and includes a rack counter, extended wash/delimer switch and easy to read temperature gauges.



External scrap tray maintains clean wash water and prevents debris from clogging the drain.

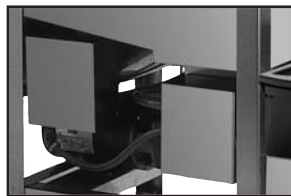

Industrial wash tank and optional booster heaters are designed for years of trouble free service.



Unique pull-pin design allows wash arms to be easily removed for cleaning.

A/A # \_\_\_\_\_



# CMA-180

High Temperature  
Single Rack  
Dishwasher

A JohnsonDiversey Company

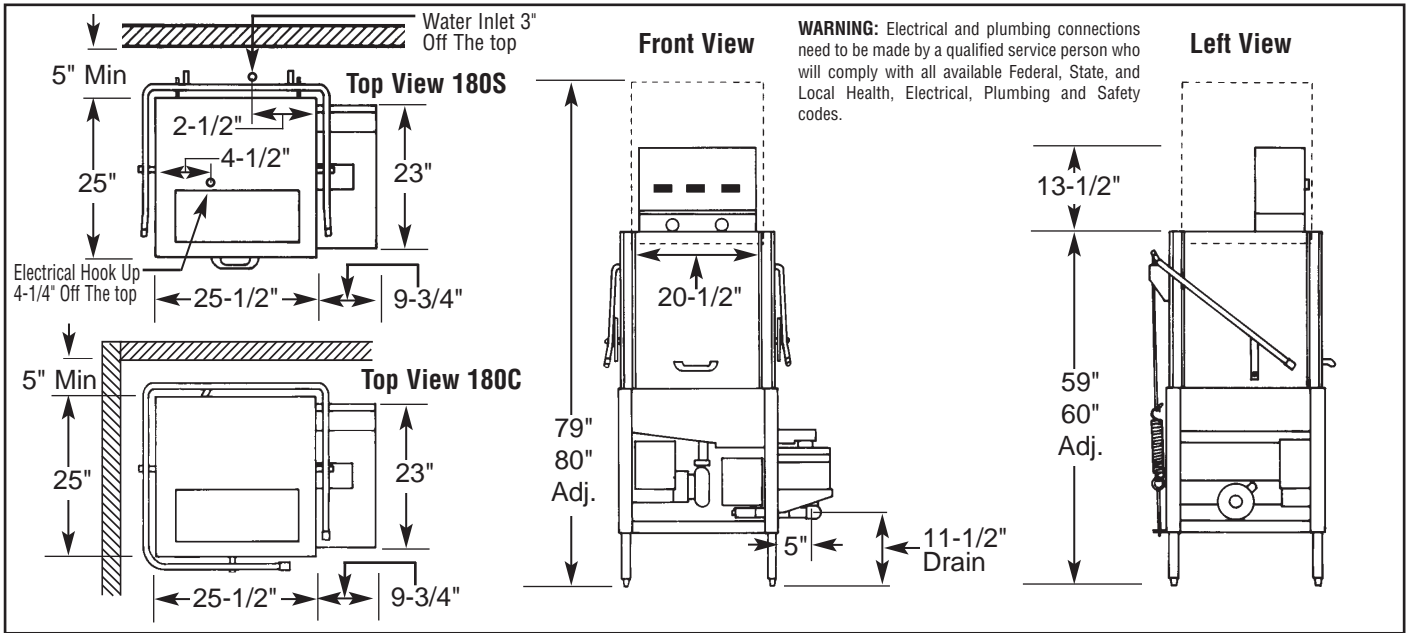

Spec. #

**Specifications:**

MODEL CMA-180	USA	METRIC	USA	METRIC
<b>WATER CONSUMPTION</b>				
PER RACK	60	60		
PER HOUR	58 GPH	(220 L)		
<b>OPERATING CYCLE</b>				
WASH TIME - SEC.	49	49		
RINSE TIME - SEC.	12	12		
TOTAL CYCLE	61	61		
<b>OPERATING CAPACITY</b>				
RACKS PER HOUR	60	60		
<b>WASH TANK CAPACITY</b>	8 GAL.	(30.3 L)		
<b>PUMP CAPACITY</b>	68 GPM	(257 LPM)		
<b>WATER REQUIREMENTS</b>				
WITHOUT BOOSTER HEATER	180°F	(82°C)		
WITH BOOSTER HEATER	140°F	(60°C)		
WATER INLET	3/4"	-		
DRAIN CONNECTION	2"	-		
RINSE PRESSURE SET	20 psi	(1.41 kg/cm <sup>2</sup> )		
<b>OPERATING TEMPERATURE</b>				
WASH-°F (MIN)	155°F-160°F	(68°C-71°C)		
RINSE-°F (MIN)	180°F-195°F	(82°C-90°C)		
<b>WASH PUMP MOTOR HP</b>			1	1
<b>DIMENSIONS</b>				
DEPTH			25"	(63.5cm)
WIDTH			25 - 1/2"	(65cm)
HEIGHT			59"-60"	(150-152cm)
STANDARD TABLE HEIGHT			34"	(86.3cm)
MAX CLEARANCE FOR DISHES			17-1/2"	(44cm)
DRAIN CONNECTION (OFF FLOOR)			11-1/2"-12-1/2"	(29-32cm)
<b>STANDARD DISHRACK</b>			1	1
DIMENSIONS			19-3/4" X 19-3/4"	(50X50cm)
<b>ELECTRICAL RATING</b>	<b>VOLTS</b>	<b>PHASE</b>	<b>AMPS</b>	
WITHOUT BOOSTER	208	1	28	
	240	1	30	
	208	3	20	
	240	3	21	
WITH BOOSTER	208	1	71	
	240	1	80	
	208	3	45	
	240	3	50	
<b>SHIPPING WEIGHT</b>				
WITHOUT BOOSTER			332#	(151kg)
WITH BOOSTER			375#	(170kg)

**Summary Specifications: Model CMA-180**

The model CMA-180 single tank, high temperature dishwasher is designed for years of trouble free service, producing sparkling results while conserving energy, water and chemicals. This machine is available with an optional "built in" booster heater, assuring a continuous supply of 180°F hot water, and is easily field convertible for either corner or straight installation. Unique soil purging system filters wash water and plate debris into an external tray. The CMA-180 is NSF, UL, CUL and CE approved.

**Available Models**

- CMA-180S Straight
- CMA-180SB Straight with booster
- CMA-180C Corner
- CMA-180CB Corner with booster

**Available Options:**

- Exhaust Fan Time Control
- Built-in 12kW booster heater
- CMA-180 Conversion Kit Corner to Straight
- CMA-180 Conversion Kit Straight to Corner
- Dual power supply connections
- Stainless steel dishtables
- Alternative electrical available for export
- Auto Fill

AIA #